

TM 11-6625-203-12

DEPARTMENT OF THE ARMY TECHNICAL MANUAL

**OPERATION AND
ORGANIZATIONAL MAINTENANCE
MULTIMETER AN/URM-105
INCLUDING MULTIMETER
ME-77/U**

This copy is a reprint which includes current
pages from Changes 4 and 6

HEADQUARTERS, DEPARTMENT OF THE ARMY

JUNE 1959

WARNING

HIGH VOLTAGE

as high as 50,000 VOLTS
may be measured with this equipment

DEATH ON CONTACT

may result if operating personnel
fail to observe safety precautions.

Be very careful when measuring voltages in excess of 200 volts. Physical contact with such voltages may result in serious injury or death. To ensure safety, turn off the equipment which is being checked before either attaching or removing the test prods at the point of measurement.

DON'T TAKE CHANCES!

TECHNICAL MANUAL

Operator and Organizational Maintenance

MULTIMETER AN/URM-105, INCLUDING MULTIMETER ME-77/U

TM 11-6625-203-12 }
CHANGES No. 4 }

HEADQUARTERS
DEPARTMENT OF THE ARMY
WASHINGTON 25, D.C., 1 February 1963

TM 11-6625-203-12, 11 June 1959, is changed as follows:

Note. The parenthetical reference to previous Changes (*example:* "Changes 3") indicates that pertinent material was published in these Changes.

Page 2. Delete paragraphs 2 and 2.1 (Changes 3, 30 Oct 62) and substitute:

2. Index of Publications

Refer to the latest issue of DA Pam 310-4 to determine whether there are new editions, changes, or additional publications pertaining to this equipment. Department of the Army Pam No. 310-4 is a current index of Technical Manuals, Technical Bulletins, Supply Bulletins, Lubrication Orders, and Modification Work Orders that are available through publications supply channels. The index lists the individual parts (-10, -20, -35P, etc) and the latest changes and revisions of each equipment publication.

2.1. Forms and Records

a. Report of Unsatisfactory Equipment. Fill out DA Form 2407 (Maintenance Request) in accordance with instructions in TM 38-750 and forward it to: Commanding Officer, U.S. Army Electronics Materiel Support Agency, ATTN: SELMS-PIE, Fort Monmouth, N.J. The form should be filled out and forwarded to report—

- (1) Receipt of defective equipment (use DD Form 6 (*b* below) if defect is due to damaged or improper shipment).
- (2) Equipment deficiencies (deadlined equipments).
- (3) Equipment shortcomings (operable, but at less than rated capability or efficiency).
- (4) Equipment improvement suggestions and recommendations.

b. Report of Damaged or Improper Shipment. Fill out and forward DD Form 6 (Report of Damaged or Improper Shipment) as prescribed in AR 700-58 (Army), NAVSANDA Publication 378, (Navy) and AFR 71-4 (Air Force).

c. Comments. Forward all comments on this publication direct to: Commanding Officer, U.S.

Army Electronics Materiel Support Agency, ATTN: SELMS-MP, Fort Monmouth, N.J. (DA Form 1598 (Record of Comments on Publications), DA Form 2496 (Disposition Form), or letter may be used.)

Page 4.

5. Components

(Superseded)

The components of Multimeter AN/URM-105 are listed in appendix III (Changes 3, 30 Oct 62). The major assemblies are illustrated in figure 1.

Page 5. Paragraph 8.

c. (Added) Dimensions. The dimensions of the multimeter are $6\frac{5}{8}$ by 4 by $3\frac{1}{4}$ inches and the weight is 2 pounds.

9. Checking Unpacked Equipment

(Superseded)

a. Inspect the equipment for damage incurred during shipment. If the equipment has been damaged, report the damage on DD Form 6 (par. 2.1b).

b. See that the equipment is complete as listed on the packing slip. If a packing slip is not available, check the equipment against the items listed in appendix III (Changes 3, 30 Oct 62). Report all discrepancies on DA Form 2407 (par. 2.1a).

Note. Shortage of a minor assembly or part that does not affect proper functioning of the equipment (electrical clips, alligator clips) should not prevent use of the multimeter.

c. If the equipment has been used or reconditioned, see whether it has been changed by a modification work order (MWO). If the multimeter has been modified, the MWO number will appear on the cover near the nomenclature plate. Check to see whether the MWO number (if any) and appropriate notations concerning the modification have been entered in this manual.

Note. Current MWO's applicable to this equipment are listed in DA Pam 310-4.

Page 10. Delete paragraphs 18 through 20 and figures 5 and 6 and substitute:

Section I. OPERATOR'S MAINTENANCE

18. Scope of Operator's Maintenance

The maintenance duties assigned to the operator of Multimeter AN/URM-105 are listed below together with a reference to the paragraphs covering the specific maintenance function. The duties assigned do not require tools or test equipment other than those listed in appendix II (Changes 3, 30 Oct 62).

- a. Daily maintenance service and inspection (par. 20).
- b. Cleaning (par. 20.1).

19. Operator's Preventive Maintenance

Operator's preventive maintenance is the systematic care, servicing, and inspection of equipment to prevent the occurrence of trouble, to reduce downtime, and to assure that the equipment is serviceable.

a. *Systematic Care.* The procedures given in paragraphs 20 and 20.1 cover systematic care essential to proper upkeep and operation of the equipment. The cleaning operations (par. 20.1) should be performed once a day. If the equipment is not used daily, however, the cleaning operations

must be performed before operation after any extended shutdown, or once a week while the equipment is kept in *standby* condition. The other items must be checked before the equipment is placed in operation after a shutdown, during operation, or after it is turned off, as specified in the applicable paragraph.

b. *Maintenance Service and Inspection.* The daily maintenance service and inspection chart (par. 20) outlines inspections to be made at daily intervals. These inspections are made to determine combat serviceability: that is, to determine that the equipment is in good general (physical) condition, in good operating condition, and likely to remain combat serviceable. To assist operators in determining and maintaining combat serviceability, the chart indicates what to inspect, how to inspect, and what the normal conditions are; the reference column lists the paragraph that contains additional information. If the defect cannot be remedied by the operator, higher echelon maintenance or repair is required. Records and reports of these inspections must be made in accordance with TM 38-750.

20. Daily Maintenance Service and Inspection Chart

Item No.	Procedure		References
	Item	Normal condition or result	
1	AN/URM-105: Inspect the equipment for—		
	a. Completeness	a. Equipment must be complete.....	a. App III (Changes 3, 30 Oct 62).
	b. Proper installation	b. Batteries are installed correctly.....	b. Par. 10.
	c. Cleanliness	c. Unit must be clean and dry inside and out; free of grease, dirt, rust, corrosion, and fungus.	c. Par. 20.1.
7	KNOBS AND SWITCHES: Check for proper mechanical action by setting each control to each of its possible settings.	Action is positive without backlash, binding, or scraping. <i>Note.</i> Knobs that require frequent tightening should have setcrews replaced.	Higher echelon maintenance required.
12	DC VOLTAGE OPERATION:		
	a. Set selector switch to 10 DC VOLTS range.	a. None.....	a. None.
	b. Connect test prods across a BA-58/U battery and note indication on meter.	b. Meter should read approximately 1.5 volts.	b. Par. 20.9.
	c. Set selector switch to 100 DC VOLTS range.	c. None.....	c. None.
	d. Remove test prods from BA-58/U battery, reconnect test prods across BA-261/U battery, and note indication on meter.	d. Meter should read approximately 22.5 volts.	d. Par. 20.9.
13	AC VOLTAGE OPERATION:		
	a. Set selector switch to 1000 AC VOLTS range.	a. None.....	a. None.

No.	Procedure		References
	Item	Normal condition or result	
14	b. Plug test prods into 117-volt ac outlet and note indication on meter.	b. Meter should read approximately 117 volts.	b. Par. 20.9.
	c. Remove test prods from 117-volt ac outlet.	c. None.....	c. None.
	RESISTANCE OPERATION:		
	a. Set selector switch to X1 OHMS range.	a. None.....	a. None.
	b. Short test prods together and adjust OHMS ADJ. control for zero indication on OHMS scale.	b. Meter should read zero resistance.....	b. Par. 20.9.
	c. Repeat a and b above for the X10, X100, X1K, and X10K OHMS ranges.	c. Same as b above.....	c. Par. 20.9.
	d. Set selector switch to OFF.....	d. None.....	d. None.

20.1. Cleaning

Inspect the exterior of the multimeter. The exterior surfaces should be clean, free from dust, dirt, grease, and fungus.

a. Remove dust and loose dirt with a clean soft cloth.

Warning: Cleaning compound is flammable and its fumes are toxic. Provide adequate ventilation. Do not use near a flame.

b. Remove grease, fungus, and ground-in dirt from the case; use a cloth dampened (not wet) with Cleaning Compound (FSN 7930-395-9542).

Caution: Do not press on the meter face (glass) when cleaning; the meter may become damaged.

c. Clean the front panel, meter, and control knobs; use a soft clean cloth. If difficulty in removing dirt occurs, dampen the cloth with water; mild soap may be used to make the cleaning more effective.

Section II. ORGANIZATIONAL MAINTENANCE

20.2. Scope of Unit Repairman's Maintenance

a. This section contains instructions covering second echelon maintenance of Multimeter AN/URM-105. It includes instructions for performing preventive maintenance services and repair functions to be accomplished by the organizational repairman.

b. Second echelon maintenance of Multimeter AN/URM-105 includes—

- (1) Preventive maintenance (pars. 20.4-20.7).
- (2) Troubleshooting (pars. 20.8 and 20.9).
- (3) Cable repair (par. 20.10).
- (4) Replacement of batteries (par. 21).

20.3. Materials Required

The tools and test equipment necessary to perform organizational maintenance are listed in appendix II (Changes 3, 30 Oct 62). The following materials are required for organizational maintenance:

- a. Cleaning compound (par. 20.1).
- b. Cleaning cloth.
- c. Electrical insulation tape (TL-192).
- d. Fine sandpaper (No. 000).
- e. Paint (par. 20.7).

20.4. Unit Repairman's Preventive Maintenance

a. Unit repairman's preventive maintenance is the systematic care, inspection, and servicing of equipment to maintain it in serviceable condition, prevent breakdowns, and assure maximum operational capability. Preventive maintenance is the responsibility of all echelons concerned with the equipment and includes the inspection, testing, and repair or replacement of parts that inspection and tests indicate would probably fail before the next scheduled periodic service. Preventive maintenance service and inspections of Multimeter AN/URM-105 at the second echelon level are made at quarterly intervals unless otherwise directed by the commanding officer.

b. Maintenance forms and records to be used and maintained on this equipment are specified in TM 38-750. Paragraph 2.1 contains additional information concerning submission of specific forms.

20.5. Quarterly Maintenance

Quarterly maintenance on Multimeter AN/URM-105 will be scheduled in accordance with the requirements of TM 38-750. All deficiencies or shortcomings will be recorded, and those not corrected during the inspection and service will be immediately reported to higher echelon using forms and procedures specified by TM 38-750. Equipment

that has a deficiency that cannot be corrected by second echelon should be deadlined in accordance with TM 38-750. Perform all the services listed in the quarterly maintenance service and inspection chart (par. 20.6) in the sequence listed. Whenever a normal condition or result is not observed, take corrective action in accordance with the information listed in the references column.

20.6. Quarterly Maintenance Service and Inspection Chart

Item No.	Procedure		References
	Item	Normal condition or result	
1	AN/URM-105: Inspect the equipment for— a. Completeness b. Proper installation c. Cleanliness d. Preservation	a. Equipment must be complete b. Batteries are installed correctly c. Unit must be clean and dry inside and out; free of grease, dirt, rust, corrosion and fungus. d. Painted surfaces must be free of bare spots, rust, and corrosion.	a. App. III (Changes 3, 30 Oct 62). b. Par. 10. c. Par. 20.1. d. Par. 20.7.
2	PUBLICATIONS: Check to see that pertinent publications are available.	a. Operator and organizational maintenance manual must be complete and in usable condition without missing pages. b. All changes pertinent to the equipment are on hand.	a. None. b. Par. 2.
3	MODIFICATION WORK ORDERS: Determine if new applicable MWO's have been published.	All URGENT MWO's have been applied to the equipment. All ROUTINE MWO's have been scheduled.	Par. 2.
4	GASKETS: Inspect waterproof gaskets for leaks and worn or loose edges.	Gaskets are clean, flexible, and in apparent good condition.	Higher echelon maintenance required.
5	PLUCKOUT ITEMS: Inspect clamps and seating of pluckout items.	All items should be properly seated and connectors should be correctly tightened.	None.
6	HARDWARE: Check for loose or missing hardware.	All bolts, nuts, and washers are present and properly tightened.	None.
7	KNOBS AND SWITCHES: Check for proper mechanical action by setting each control to each of its possible settings.	Action is positive without backlash, binding, or scraping. <i>Note.</i> Knobs that require frequent tightening should have setscrews replaced.	Higher echelon maintenance required.
8	CABLES: Inspect cables for breaks, cuts, kinks, deterioration, strain, and fraying.	Cables should not have any breaks, cuts, kinks, deterioration, strain, and fraying.	Par. 20.10.
9	METER: Inspect meter for damaged and broken glass.	Meter should not have any broken glass....	Higher echelon maintenance required.
10	RESISTORS AND INSULATORS: Inspect resistors and insulators for cracks, chipping, blistering, discoloration, and moisture.	All resistors and insulators should be free of cracks, chipping, blistering, discoloration, and moisture.	Higher echelon maintenance required.
11	BATTERIES: Inspect dry batteries for dirt, loose terminals, and leakage.	Batteries should be free of dirt and leakage.	Par. 21.
12	DC VOLTAGE OPERATION: a. Remove four retaining screws that secure panel to case and remove panel. b. Set selector switch to 10DC VOLTS range. c. Connect test prods across one of BA-58/U batteries and note indication on meter.	a. None b. None c. Meter should read approximately 1.5 volts.	a. None. b. None. c. Par. 20.9.

Item No.	Procedure		References
	Item	Normal condition or result	
13	d. Set selector switch to 100 DC VOLTS RANGE.	d. None	d. None.
	e. Remove test prods from BA-58/U battery, reconnect test prods across BA-261/U battery, and note indication on meter.	e. Meter should read approximately 22.5 volts.	e. Par. 20.9.
	f. Remove test prods from BA-261/U battery, replace panel in case, and secure panel with four retaining screws.	f. None	f. None.
	AC VOLTAGE OPERATION:		
	a. Set selector switch to 1,000 AC VOLTS RANGE.	a. None	a. None.
	b. Plug test prods into 117-volt ac outlet and note indication on meter.	b. Meter should read approximately 117 volts.	b. Par. 20.9.
14	c. Remove test prods from 117-volt ac outlet.	c. None	c. None.
	RESISTANCE OPERATION:		
	a. Set selector switch to X1 OHMS range.	a. None	a. None.
	b. Short test prods together and adjust OHMS ADJ. control for zero indication on OHMS scale.	b. Meter should read zero resistance	b. Par. 20.9.
c. Repeat a and b above for the X10, X100, X1K, and X10K OHMS ranges.	c. Same as b above	c. Par. 20.9.	
d. Set selector switch to OFF	d. None	d. None.	

20.7. Cleaning and Touchup Painting Instructions

Remove rust and corrosion from metal surfaces by lightly sanding them with fine sandpaper. Brush

two thin coats of paint on the bare metal to protect it from further corrosion. Refer to applicable cleaning and refinishing practices specified in TM 9-213.

Section III. TROUBLESHOOTING

20.8. General Troubleshooting Information

Troubleshooting the multimeter is based upon the operational check contained in the quarterly maintenance service and inspection chart (par. 20.6). To troubleshoot the equipment, perform all functions starting with Item No. 12 of the quarterly maintenance service and inspection chart and proceed through the items until an abnormal

condition or result is observed. When an abnormal condition or result is observed, note the item number and turn to the corresponding item number in the troubleshooting chart (par. 20.9). Perform the checks and corrective actions indicated in the troubleshooting chart. If the corrective measures indicated do not result in correction of the trouble, higher echelon maintenance is required.

20.9. Troubleshooting Chart

Item No.	Trouble symptom	Probable trouble	Checks and corrective measures
12	c. No meter indication	c. Open resistor in dc voltmeter circuit.	c. Higher echelon maintenance required.
	e. No meter indication	d. Same as c above	e. Same as c above.
13	b. No meter indication	b. Open resistor in ac voltmeter circuit.	b. Higher echelon maintenance required.
	b. Meter pointer cannot be adjusted to zero.	b. Weak batteries	b. Replace defective battery (par. 21).
14	c. Same as b above	c. Same as b above	c. Same as b above.

20.10. Test Lead Repair

Use electrical insulation tape to repair all breaks, cuts, kinks, deterioration, strain, and fraying in the test leads. If the tips of the test prods are broken, replace them.

Page 19, appendix I.

Delete "TM 11-6625-203-12P" and its title.

Add the following items to appendix I:

AR 700-58	Report of Damaged or Improper Shipment.
DA Pam 310-4	Index of Technical Manuals, Technical Bulletins, Lubrication Orders, and

SB 11-6

TM 9-213

TM 11-6625-203-20P

TM 38-750

Modification Work Orders.

Dry Battery Supply Data.

Painting Instructions for Field Use.

Organizational Maintenance Repair Parts and Special Tool Lists Multimeters AN/URM-105 and ME-77/U.

The Army Equipment Record System and Procedures.

By Order of the Secretary of the Army:

EARLE G. WHEELER,
General, United States Army,
Chief of Staff.

Official:

J. C. LAMBERT,
Major General, United States Army,
The Adjutant General.

Distribution:

Active Army:

DASA (6)	USA Strat Comm Comd (4)	5-35	6-316
USASA (2)	Redstone Arsenal (5)	5-36	6-325
CNGB (2)	USA Cml Cen (5)	5-37	6-326
CSigO (5)	USA Photo Agcy (5)	5-38	6-330
CofT (1)	Raritan Arsenal (5)	5-45	6-345
CofEngrs (1)	USA Ammo Proc and Sup Agcy (5)	5-46	6-346
TSG (1)	Benicia Arsenal (5)	5-47	6-355
AMC (5)	1st FA Msl Bde (5)	5-49	6-356
USCONARC (5)	1st GM Bde (5)	5-52	6-401
ARADCOM (2)	Gen Hosp (5)	5-78	6-425
ARADCOM Rgn (2)	APG (5)	5-115	6-426
OS Maj Comd (3)	USA Polar R&D Cen (5)	5-116	6-500
OS Base Comd (2)	USASATSA (5)	5-118	6-500 AA
LOGCOMD (2)	AAF (CONUS) (5)	5-145	6-501
MDW (1)	USMA (5)	5-146	6-525
Armies (2)	USA Inf Cen (5)	5-147	6-535
Corps (2)	USA SPWAR Cen (5)	5-148	6-536
USA Tng Cen (2)	USA Exhibit Unit (5)	5-155	6-537
USA CD Agcy (1)	USAWC (5)	5-156	6-545
USA Elct Comd (5)	Mil Msn: Guatemala, Venezuela,	5-157	6-555
USA Msl Comd (3)	Paraguay (5)	5-278	6-558
Svc Colleges (2)	Units organized under following	5-348	6-585
Br Svc Sch (2)	TOE's: (2 each)	5-372	6-615
Army Dep (2) except	1-7	5-376	6-616
Lexington, Tobyhanna (12)	1-17	5-500 AA-AD	6-631
Ft Worth (8) Sacramento (17)	1-37	5-600	6-635
Sig Dep (OS) (12)	1-55	5-605	6-636
GEN DEP (OS) (2)	1-56	5-617	7
Sig Sec, Gen Dep (5)	1-57	6-100	7-4
WRAMC (1)	1-58	6-101	7-11
USA Trans Tml Comd (1)	1-67	6-115	7-12
Army Tml (1)	1-75	6-116	7-15
POE (1)	1-76	6-125	7-16
OSA (1)	1-77	6-126	7-19
AFIP (1)	1-78	6-135	7-25
AMS (1)	1-107	6-136	7-26
Army Pictorial Cen (2)	1-127	6-155	7-27
USA Mobility Spt Cen (1)	1-137	6-156	7-31
Yuma Test Station (2)	1-207	6-165	7-32
USARCARIB Sig Agcy (1)	3-266	6-166	7-35
USA Sig Fld Maint Shops (3)	5-5	6-175	7-36
USA Corps (3)	5-6	6-176	7-42
JBUSMC (2)	5-7	6-200	7-45
Instl (2) except Ft Monmouth (63)	5-8	6-201	7-47
USA Elct Mat Agcy (25)	5-15	6-225	7-46
Chicago Proc Dist (1)	5-16	6-226	7-52
USA Elct R&D Activity, Ft	5-17	6-300	8-15
Huachuca (2)	5-25	6-301	8-16
USA Elct R&D Activity (WSMR)	5-26	6-302	8-35
(13)	5-27	6-315	8-36

8-75	11-98	17-116	44-35
8-76	11-117	17-117	44-36
8-137	11-155	17-408	44-37
8-500 AA-AH	11-156	19-27	44-67
9-22	11-157	19-29	44-85
9-47	11-158	19-35	44-86
9-65	11-165	19-37	44-87
9-66	11-166	19-55	44-102
9-86	11-167	19-57	44-112
9-87	11-237	19-217	44-235
9-217	11-500 AA-AE	19-500 AA-AE	44-236
9-227	RM-RT	29-1	44-237
9-337	11-555	29-21	44-246
9-500 AA-AC	11-587	29-25	44-435
10-22	11-592	29-26	44-436
10-105	11-597	29-35	44-437
10-106	11-608	29-36	44-445
10-202	12-17	29-56	44-446
10-206	12-32	29-307	44-447
10-377	17	30-19	44-448
10-445	17-2	30-21	44-535
10-446	17-4	30-22	44-536
11-5	17-17	30-25	44-537
11-6	17-22	30-26	44-545
11-7	17-25	30-28	44-546
11-8	17-26	30-29	44-547
11-15	17-27	30-500 AA-AE	44-548
11-16	17-32	30-600 AA-AE	45-500 AA-AC
11-17	17-35	32-56	55-12
11-18	17-36	32-57	55-11
11-36	17-37	32-67	55-18
11-37	17-42	32-78	55-28
11-38	17-45	33-77	55-38
11-39	17-46	33-105	55-46
11-45	17-51	33-106	55-47
11-46	17-52	33-107	55-57
11-55	17-55	33-500 AA-AC	55-75
11-56	17-56	37	55-76
11-57	17-57	37-42	55-78
11-58	17-65	39-51	55-116
11-67	17-66	39-52	55-126
11-68	17-85	39-401	55-127
11-85	17-86	44-2	55-128
11-86	17-105	44-8	55-129
11-87	17-106	44-12	55-135
11-95	17-107	44-15	55-157
11-96	17-108	44-16	57
11-97	17-115	44-17	57-4

NG: State AG (3) units same as active Army except allowance is one copy to each unit.

USAR: None.

For explanation of abbreviations used, see AR 320-50.

CHANGE }
No. 6 }

HEADQUARTERS
DEPARTMENT OF THE ARMY
WASHINGTON, DC, 26 December 1975

**OPERATOR AND ORGANIZATIONAL MAINTENANCE MANUAL
MULTIMETERS AN/URM-105 AND AN/URM-105C INCLUDING
MULTIMETERS ME-77/U AND MZ-77C/U**

TM 11-6625-203-12, 11 June 1959, is changed as follows:

Title is changed to read as shown above.

Page 2, paragraph 1. Delete paragraph 1 and substitute:

1. Scope

a. This manual describes Multimeters AN/URM-105 (NSN 6625-00-581-2036) and AN/URM-105C (NSN 6625-00-999-6282) and includes the operation and organizational maintenance of the equipment.

b. The major components of the AN/URM-105 and the AN/URM-105C are the Multimeter ME-77/U (NSN 6625-00-284-0854) and Multimeter ME-77C/U (NSN 6625-00-999-6625) respectively, and are referred to in this manual as *multimeter*.

c. Throughout this manual, all references to Multimeter AN/URM-105 and Multimeter ME-77/U will also apply to the AN/URM-105C and the ME-77C/U, respectively.

Paragraph 2. Delete paragraph 2 and substitute:

2. Indexes of Publications

a. *DA Pam 310-4*. Refer to the latest issue of DA Pam 310-4 to determine whether there are new editions, changes, or additional publications pertaining to the equipment.

¹ This change supersedes C 3, 30 October 1962, and C 5, 14 May 1974.

b. *DA Pam 310-7*. Refer to DA Pam 310-7 to determine whether there are modification work orders (MWO's) pertaining to the equipment.

Paragraph 2.1. Delete paragraph 2.1 and substitute:

2.1. Forms and Records

a. *Reports of Maintenance and Unsatisfactory Equipment*. Maintenance forms, records, and reports which are to be used by maintenance personnel at all maintenance levels are listed in and prescribed by TM 38-750.

b. *Report of Packaging and Handling Deficiencies*. Fill out and forward DD Form 6 (Packaging Improvement Report) as prescribed in AR 700-58/NAVSUPINST 4030.29/AFR 71-13/MCO P4030.29A, and DSAR 4145.8.

c. *Discrepancy in Shipment Report (DISREP) (SF 361)*. Fill out and forward Discrepancy in Shipment Report (DISREP) (SF 361) as prescribed in AR 55-38/NAVSUPINST 4610.33 A/AFR 75-18/MCO P4610.19B, and DSAR 4500.15.

Paragraph 2.2. Delete paragraph 2.2 and substitute:

2.2. Recommendation for Equipment Publication Improvements

The reporting of errors, omissions, and recommendations for improving this publication by the individual user is encouraged. Reports should be submitted on DA Form 2028 (Recommended Changes to Publications and Blank Forms) and forwarded direct to Commander, US Army

Electronics Command, ATTN: AMSEL-MA-Q,
Fort Monmouth, NJ 07703.

**5. Items Comprising an Operable Multi-
meter AN/URM-105 and Multimeter
AN/URM-105C**

Page 4, paragraph 5. Delete paragraph 5 and
substitute:

a. Multimeter AN/URM-105

NSN	Qty	Nomenclature, part No., and mfr code
6625-00-581-2036		Multimeter AN/URM-105 consisting of:

NOTE

The part number is followed by the applicable 5-digit Federal supply code for manufacturers (FSCM) identified in SB 708-42 and used to identify manufacturer, distributor, or Government agency, etc.

NOTE

Dry batteries shown are used with the equipment but are not considered part of the equipment. They will not be preshipped automatically but are to be requisitioned in quantities necessary for the particular organization in accordance with SB 11-6.

6625-00-284-0854	1	Multimeter ME-77/U: 0 to 1,000 volts ac, 0 to 20 megohms, 0 to 100 amperes, 3 9/32 in. x 4 1/8 in.
6185-00-120-1030	2	Battery BA-58: (installed in equip)
6185-00-160-7159	1	Battery BA-261/U: (installed in equip)
5940-00-702-5260	1	Clip, Electrical: SM-C-145746-2, 80063 (installed in equip)
5940-00-702-5256	1	Clip, Electrical: SM-C-145746-1, 80063 (installed in equip)
6625-00-887-9910	2	Clip, Assembly: SC-DL-20735, 80063 (installed in equip)
6625-00-999-6282		Multimeter AN/URM-105C consisting of:

NOTE

The part number is followed by the applicable 5-digit Federal supply code for manufacturers (FSCM) identified in SB 708-42 and used to identify manufacturer, distributor, or Government agency, etc.

NOTE

Dry batteries shown are used with the equipment but are not considered part of the equipment. They will not be preshipped automatically but are to be requisitioned in quantities necessary for the particular organization in accordance with SB 11-6.

6625-00-999-6625	1	Multimeter ME-77C/U: 0 to 1,000 volts ac, 0 to 20 megohms, 0 to 100 amperes, 3 9/32 in. x 4 1/8 in.
6185-00-120-1030	2	Battery BA-58: (installed in equip)
6185-00-160-7159	1	Battery BA-261/U: (installed in equip)
5940-00-702-5260	1	Clip, Electrical: SM-C-145746-2, 80063 (installed in equip)
5940-00-702-5256	1	Clip, Electrical: SM-C-145746-1, 80063 (installed in equip)
6625-00-887-9910	2	Clip, Assembly: SC-DL-20735, 80063 (installed in equip)

Paragraph 6. After paragraph 6, add:

Page 5, paragraph 9a line 3. Delete “(para 2.1b).”

6.1. Differences in Models

Multimeter AN/URM-105C is similar to Multimeter AN/URM-105. The major difference in the two models is in the maintenance parts.

Subparagraph b. Delete the second sentence.

Page 19, appendix I. Delete appendix I and substitute:

APPENDIX A

REFERENCES

DA Pam 310-4	Index of Technical Manuals, Technical Bulletins, Supply Manuals, (Types 7, 8 and 9), Supply Bulletins, and Lubrication orders.
DA Pam 310-7	US Army Equipment Index of Modification Work Orders.
SB 11-573	Painting and Preservation Supplies Available for Field Use for Electronics Command Equipment.
SB 38-100	Preservation, Packaging, Packing and Marng Materials, Supplies, and Equipment Used by the Army.
TB 43-0118	Field Instructions for Painting and Preserving Electronics Command Equipment, including Camouflage Pattern Painting of Electrical Equipment Shelters.
TM 11-5102	Resistors, Decade ZM-16/U, ZM-16A/U, and ZM-16B/U (TO 33AA6-6-1).
TM 11-6625-277-14	Operator's, Organizational, Direct Support, and General Support Maintenance Manual: Meter Test Sets TS-682/GSM-1 and TS-682A/GSM-1 (NSN 6625-00-669-0747).
TM 11-6625-366-15	Operator's, Organizational, DS, GS, and Depot Maintenance Manual: Multimeter TS-352B/U.
TM 38-750	The Army Maintenance Management Systems (TAMMS).
TM 740-90-1	Administrative Storage of Equipment.
TM 750-244-2	Procedures for Destruction of Electronics Materiel to Prevent Enemy Use (Electronics Command).

Page 20, appendix II. Delete appendix II and substitute:

APPENDIX B

MAINTENANCE ALLOCATION

Section I. INTRODUCTION

B-1. General

This appendix provides a summary of the maintenance operations for AN/URM-105. It authorizes categories of maintenance for specific maintenance functions on repairable items and components and the tools and equipment required to perform each function. This appendix may be used as an aid in planning maintenance operations.

B-2. Maintenance Function

Maintenance functions will be limited to and defined as follows:

a. Inspect. To determine the serviceability of an item by comparing its physical, mechanical,

and/or electrical characteristics with established standards through examination.

b. Test. To verify serviceability and to detect incipient failure by measuring the mechanical or electrical characteristics of an item and comparing those characteristics with prescribed standards.

c. Service. Operations required periodically to keep an item in proper operating condition, i.e., to clean, preserve, drain, paint, or to replenish fuel/lubricants/hydraulic fluids or compressed air supplies.

d. Adjust. Maintain within prescribed limits by bringing into proper or exact position, or by

setting the operating characteristics to the specified parameters.

e. Align. To adjust specified variable elements of an item to about optimum or desired performance.

f. Calibrate. To determine and cause corrections to be made or to be adjusted on instruments or test measuring and diagnostic equipment used in precision measurement. Consists of the comparison of two instruments, one of which is a certified standard of known accuracy, to detect and adjust any discrepancy in the accuracy of the instrument being compared.

g. Install. The act of emplacing, seating, or fixing into position an item, part, module (component or assembly) in a manner to allow the proper functioning of the equipment/system.

h. Replace. The act of substituting a serviceable like-type part, subassembly, model (component or assembly) for an unserviceable counterpart.

i. Repair. The application of maintenance services (inspect, test, service, adjust, align, calibrate, replace) or other maintenance actions (welding, grinding, riveting, straightening, facing, remachining, or resurfacing) to restore serviceability to an item by correcting specific damage, fault, malfunction, or failure in a part, subassembly, module/component/assembly, end item or system. This function does not include the trial and error replacement of running spare type items such as fuses, lamps, or electron tubes.

j. Overhaul. That periodic maintenance effort (service/action) necessary to restore an item to a completely serviceable/operational condition as prescribed by maintenance standards (e.g., DMWR) in appropriate technical publications. Overhaul is normally the highest degree of maintenance performed by the Army. Overhaul does not normally return an item to like-new condition.

k. Rebuild. Consists of those services/actions necessary for the restoration of unserviceable equipment to a like-new condition in accordance with original manufacturing standards. Rebuild is the highest degree of material maintenance applied to Army equipment. The rebuild operation includes the act of returning to zero those

age measurements (hours, miles, etc.) considered in classifying Army equipment/components.

B-3. Column Entries

a. Column 1, Group Number. Column 1 lists group numbers, the purpose of which is to identify components, assemblies, subassemblies and modules with the next higher assembly.

b. Column 2, Component/Assembly. Column 2 contains the noun names of components, assemblies, subassemblies, and modules for which maintenance is authorized.

c. Column 3, Maintenance Functions. Column 3 lists the functions to be performed on the item listed in column 2. When items are listed without maintenance functions, it is solely for purpose of having the group numbers in the MAC and RPSTL coincide.

d. Column 4, Maintenance Category. Column 4 specifies, by the listing of a "worktime" figure in the appropriate subcolumn(s), the lowest level of maintenance authorized to perform the function listed in column 3. This figure represents the active time required to perform that maintenance function at the indicated category of maintenance. If the number or complexity of the tasks within the listed maintenance function vary at different maintenance categories, appropriate "worktime" figures will be shown for each category. The number of man-hours specified by the "worktime" figure represents the average time required to restore an item (assembly, subassembly, component, module, end item or system) to a serviceable condition under typical field operating conditions. This time includes preparation time, troubleshooting time and quality assurance/quality control time in addition to the time required to perform the specific tasks identified for the maintenance functions authorized in the maintenance allocation chart. Subcolumns of column 4 are as follows:

C...Operator/crew
O...Organizational
F...Direct support
H...General support
D...Depot

e. Column 5, Tools and Equipment. Column 5 specifies by code, those common tool sets (not individual tools) and special tools, test, and

support equipment required to perform the designated function.

B-4. Tool and Test Equipment Requirements (Table 1)

a. *Tool or Test Equipment Reference Code.* The numbers in this column coincide with the numbers used in the tools and equipment column of the MAC. The numbers indicate the applicable tool or test equipment for the maintenance functions.

b. *Maintenance Category.* The codes in this column indicate the maintenance category allocated the tool or test equipment.

c. *Nomenclature.* This column lists the noun name and nomenclature of the tools and test equipment required to perform the maintenance functions.

d. *National/NATO Stock Number.* This column lists the National/NATO stock number of the specific tool or test equipment.

e. *Tool Number.* This column lists the manufacturer's part number of the tool followed by the Federal Supply Code for manufacturers (5-digit) in parentheses.

Section II. MAINTENANCE ALLOCATION CHART
FOR MULTIMETERS AN/URM-105 AND AN/URM-105C

(1) Group number	(2) Component assembly	(3) Maintenance function	(4) Maintenance category					(5) Tools and equipment
			C	O	F	H	D	
00	MULTIMETERS AN/URM-105 AND AN/URM-105C	Inspect		0.2				
		Service		0.5				
		Replace		0.2				5
		Repair				1.0		4
		Test				1.5	1.5	1 thru 4
		Rebuild					5.0	1 thru 4
01	MULTIMETER ME-77/U and ME-77C/U	Inspect		0.2				
		Service		0.5				
		Repair				1.0		4
		Test				1.5	1.5	1 thru 4
02	BOARD, PRINTED CIRCUIT	Replace				1.0		4
03	CASE, METER	Replace				0.5		4
04	COVER	Replace				0.1		

Table 1. Tool and Test Equipment Requirements for Multimeters AN/URM-105 and AN/URM-105C

Tool or test equipment ref code	Maintenance category	Nomenclature	National/NATO stock number	Tool number
1	H, D	DECADE RESISTOR ZM-16/U	6625-00-669-0266	
2	H, D	METER TEST SET TS-682A/G	6625-00-669-0747	
3	H, D	MULTIMETER TS-352B/U	6625-	
4	H, D	TOOL KIT, ELECTRONIC EQUIPMENT TK-100/G	51	
5	O	TOOLS AND TEST EQUIPMENT AVAILABLE TO USER REPAIRMAN BY VIRTUE OF HIS ASSIGNED MISSION		

By Order of the Secretary of the Army:

FRED C. WEYAND
General, United States Army
Chief of Staff

Official:

PAUL T. SMITH
Major General, United States Army
The Adjutant General

Distribution:

Active Army:

USASA (2)
Dir of Trans (1)
COE (1)
TSG (1)
USAARENBD (1)
AMC (1)
MICOM (2)
TECOM (2)
TRADOC (2)
ARADCOM (2)
ARADCOM Rgn (2)
OS Maj Comd (4)
LOGCOMD (3)
USACC (4)
MDW (1)
Armies (2)
Corps (2)
Div (2)
Bde (2)
Regt (2)
Bn (2)
HISA (Ft Monmouth) (33)
Ft Gillem (10)
Ft Gordon (10)

Ft Huachuca (10)
Ft Carson (5)
Ft Richardson (ECOM Ofc) (2)
WSMR (1)
Svc Colleges (1)
USASESS (5)
USAINTC (3)
USAADS (2)
USAFAS (2)
USAARMS (2)
USAIS (2)
USAES (2)
SAAD (30)
LBAD (14)
TOAD (14)
SHAD (3)
ATS (1)
MAAG (1)
WRAMC (1)
USARMIS (1)
USAERDAA (1)
USAERDAW (1)
Sig FLDMS (1)

ARNG: State AG (3); Units—Same as Active Army except allowance is one (1) copy each.

USAR: None

For explanation of abbreviations used, see AR 310-50.

TECHNICAL MANUAL }
 No. 11-6625-203-12 }

HEADQUARTERS,
 DEPARTMENT OF THE ARMY
 WASHINGTON 25, D. C., 11 June 1959

MULTIMETER AN/URM-105, INCLUDING MULTIMETER ME-77/U

	Para- graph	Page
CHAPTER 1. INTRODUCTION		
Section I. General		
Scope.....	1	2
Forms and records.....	2	2
II. Description and data		
Purpose and use.....	3	2
Technical characteristics.....	4	3
Components of Multimeter AN/URM-105	5	4
Description.....	6	4
Additional equipment required.....	7	4
CHAPTER 2. SERVICE UPON RECEIPT OF EQUIPMENT		
Unpacking.....	8	5
Checking unpacked equipment.....	9	5
Installation of batteries.....	10	5
CHAPTER 3. OPERATING INSTRUCTIONS		
Damage from improper settings.....	11	7
Controls.....	12	7
Dc voltage measurements.....	13	7
Ac voltage measurements.....	14	8
Resistance measurements.....	15	8
Preparation for current measurements.....	16	8
Stopping procedure.....	17	9
4. MAINTENANCE INSTRUCTIONS		
Scope of organizational maintenance.....	18	10
Tools, test equipment, and materials required	19	10
Preventive maintenance.....	20	10
Replacement of batteries.....	21	13
5. AUXILIARY EQUIPMENT		
Description and use of auxiliary equipment.....	22	14
Direct current measurements.....	23	14
High voltage measurements.....	24	16
6. SHIPMENT, LIMITED STORAGE, AND DEMOLITION TO PREVENT ENEMY USE		
Section I. Shipment and limited storage		
Disassembly of equipment.....	25	18
Repackaging for shipment or limited storage.....	26	18
Section II. Demolition of materiel to prevent enemy use		
Authority for demolition.....	27	18
Methods of destruction.....	28	18
APPENDIX I. REFERENCES.....		19
II. MAINTENANCE ALLOCATION CHART FOR MULTIMETER AN/URM-105.....		20

CHAPTER 1

INTRODUCTION

Section I. GENERAL

1. Scope

a. This manual describes Multimeter AN/URM-105, its operation, and organizational maintenance. It covers the operation, cleaning, and inspection of the equipment.

b. Throughout this manual, Multimeter ME-77/U, the major component of the AN/URM-105, is referred to as *multimeter*.

2. Forms and Records

a. Unsatisfactory Equipment Reports. Fill out and forward DA Form 468 (Unsatisfactory Equipment Report) to the Commanding Officer, U.S. Army Signal Equipment Support Agency, Fort Monmouth, N.J., as prescribed in AR 700-38.

b. Report of Damaged or Improper Shipment. Fill out and forward DD Form 6 (Report of

Damaged or Improper Shipment) as prescribed in AR 700-58 (Army), Navy Shipping Guide, Article 18504 (Navy), and AFR 71-4 (Air Force).

c. Preventive Maintenance Form. Prepare DA Form 11-266 (figs. 5 and 6) (Maintenance Check List for Signal Equipment (Test Equipment)) in accordance with instructions on the form.

d. Parts List Form. Forward DA Form 2028 (Recommended Changes to DA Technical Manual Parts Lists or Supply Manuals 7, 8, and 9) directly to the Commanding Officer, U. S. Army Signal Equipment Support Agency, Fort Monmouth, N. J., with comments on parts listings.

e. Comments on Manual. Forward all other comments on this publication directly to the Commanding Officer, U.S. Army Signal Publications Agency, Fort Monmouth, N.J.

Section II. DESCRIPTION AND DATA

3. Purpose and Use

a. Multimeter AN/URM-105 is a voltmeter-ohmmeter that is used to measure direct current (dc) voltage, alternating current (ac) voltage, and resistance.

b. Additional accessories are available to extend

the dc voltage range and to enable the use of the multimeter as an ammeter.

- (1) The dc voltage range may be extended up to 50,000 volts with the use of external multipliers (par. 22*b* and *c*).
- (2) Current measurements up to 100 amperes may be made with the use of an external shunt (par. 22*a*).

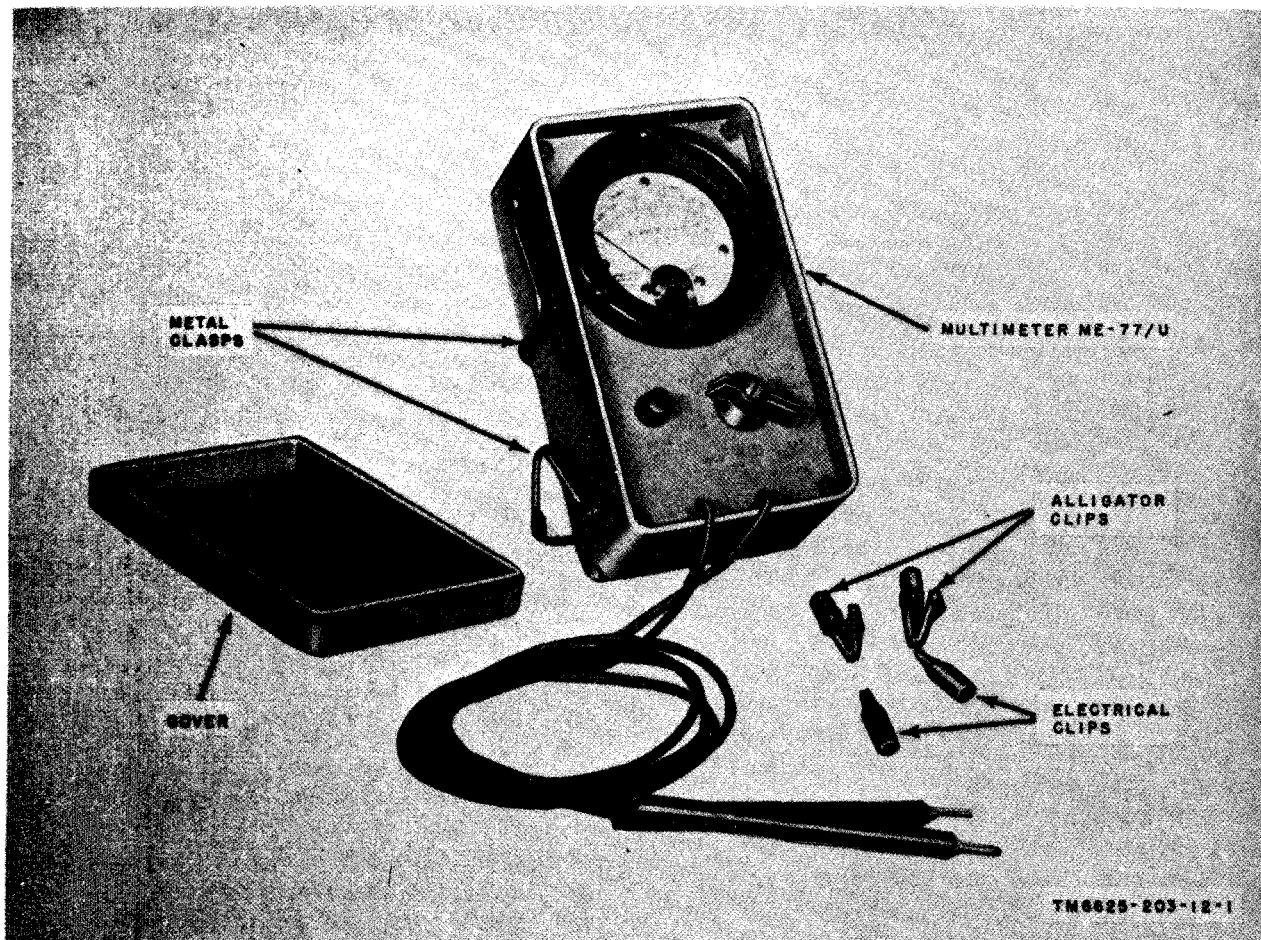

Figure 1. Multimeter AN/URM-105.

4. Technical Characteristics

Ranges :

Dc voltage -----	0 to 1, 10, 100, and 1,000 volts at 20,000 ohms per volt.
Ac voltage -----	0 to 10, 100, and 1,000 volts at 1,000 ohms per volt.
Resistance -----	0 to 2,000, 20,000, 200,000, 2,000,000 and 20,000,000 ohms.
Direct current -----	External shunt required.
Frequency range -----	30 cycles to 10,000 cycles.
Usable temperature range ---	0° F. to +131° F.

Meter :

Type -----	3½ inch, sealed, flush mounting, ruggedized.
Current sensitivity -----	50-microamperes dc.

Meter-Continued

Voltage sensitivity ----- 0.25 volt $\pm 2\%$ of full scale.
Terminal impedance ----- 5,000 ohms.

Accuracy :

Dc ranges -----	$\pm 3\%$ of full scale value at 77° F. ; $\pm 5\%$ at 0° F. and 131° F.
Ac ranges -----	$\pm 4\%$ of full scale value at 77° F. ; $\pm 7\%$ at 0° F. and 131° F.
Resistance -----	$\pm 5\%$ of indicated value at 77° F. ; $\pm 7\%$ at 0° F. and 131° F.

Power supply for resistance measurements. Battery: 1.5 volts on X1, X10, and X100 ranges; 22.5 volts on X1K and X10K ranges.

5. Components of Multimeter AN/URM-105

(fig. 1)

Quantity	Item	Height (in.)	Depth (in.)	Width (in.)	Unit weight (lb)
1	Multimeter ME-77/U	6½	4	3¼	2
2	Alligator clips (1 red, 1 black).				
2	Electrical clips. (1 red, 1 black).				

6. Description

a. Multimeter AN/URM-105 consists of Multimeter ME-77/U (*b* below) and several clips (par. 5).

b. Multimeter ME-77/U, the major component of the AN/URM-105, consists of a panel (fig. 3) mounted in a plastic case. The operating controls (fig. 4) and the meter are mounted on the face of the panel. All circuit components are secured to the rear of the panel. The test leads are permanently attached to the printed circuit board and secured to the rear of the panel the test leads extend through the panel. The cover is secured

with metal clasps (fig. 1); the lower clasp may be used as a stand for the multimeter.

7. Additional Equipment Required

The following equipment is not supplied as part of Multimeter ME-77/U but is needed for use with it:

a. Two Batteries BA-58/U, 1.5 volts, are required to supply power for resistance measurements on the X1, X10, and X100 ranges.

b. One Battery BA-261/U, 22.5 volts, is required to supply power for resistance measurements on the X1K and X10K ranges.

CHAPTER 2

SERVICE UPON RECEIPT OF EQUIPMENT

8. Unpacking (fig. 2)

a. Packaging Data. The multimeter is packed for shipment in a corrugated carton $7\frac{1}{4}$ by $5\frac{1}{2}$ by $4\frac{3}{4}$ inches; the weight is 2.5 pounds, and the volume is approximately 190 cubic inches.

b. Unpacking.

- (1) Open the corrugated carton and fold back the top flaps.
- (2) Remove the wrapped multimeter; open the corrugated fiberboard and remove the multimeter.
- (3) Remove the envelopes that contain the

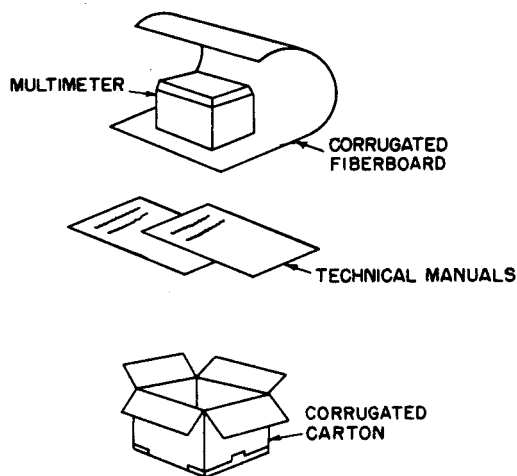

TM6625-203-12-2

Figure 2. Packaging diagram.

technical manuals; open the envelopes and remove the manuals.

9. Checking Unpacked Equipment

a. Inspect the equipment for possible damage incurred during shipment. If the equipment has been damaged, refer to paragraph 2.

b. Check the equipment against the packing list. When no packing list accompanies the equipment, use the table of components (par. 5) as a general check. If the equipment is incomplete, refer to paragraph 2.

10. Installation of Batteries

Install the batteries (par. 7) in the multimeter as follows:

a. Lift the metal clasps (fig. 1) away from the case and remove the cover.

b. Remove the retaining screws that secure the panel to the case and remove the panel.

c. Observing the polarity indicated on the battery holder (fig. 3), install Battery BA-261/U and Batteries BA-58/U. Check to be sure that the batteries are firmly seated against both contacts.

d. Replace the panel in the case and check for sufficient battery voltage (par. 21).

e. Secure the panel to the case with the retaining screws.

f. Coil the test leads on top of the panel; place the alligator clips and electrical clips on the panel.

g. Replace the cover and secure it with the metal clasps.

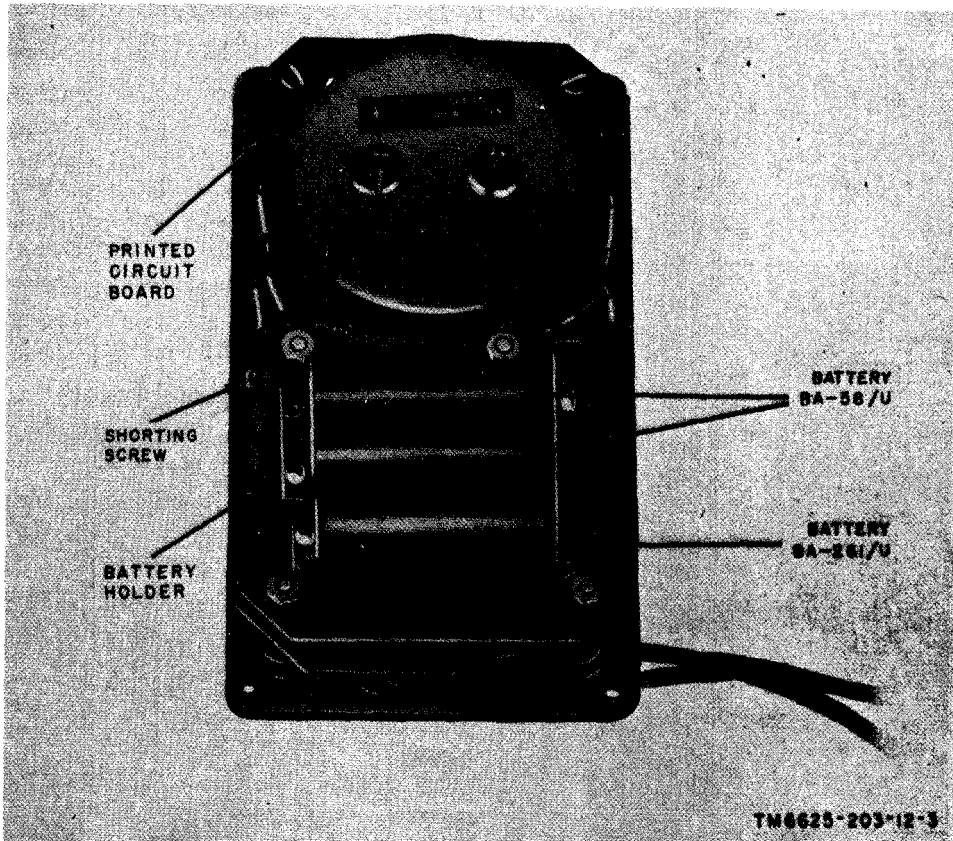

Figure 3. Multimeter ME-77/U, panel, rear view.

CHAPTER 3

OPERATING INSTRUCTIONS

11. Damage from Improper Settings

a. Improper setting of the selector switch (fig. 4) may damage the multimeter. When measuring unknown voltage values, start at the highest range (1,000 volts) and reduce the setting of the selector switch one step at a time until the meter pointer indicates near the center of the scale.

b. The multimeter is shipped with the shorting screw (fig. 3) in the open position. When making direct current measurements (par. 23), the shorting screw must be placed in the closed position. When the shorting screw is in the closed position and the selector switch is in the EXT. SHUNT position, the meter is connected directly in parallel with the test leads. If the meter is connected directly into a circuit without the use of an external shunt, the meter will become damaged.

12. Controls

Control or indicator	Function												
Selector switch (fig. 4).	<p>Selects mode of operation and desired voltage or resistance range:</p> <table style="width: 100%; border-collapse: collapse;"> <thead> <tr> <th style="text-align: left; font-size: small;"><i>Switch position</i></th> <th style="text-align: left; font-size: small;"><i>Action</i></th> </tr> </thead> <tbody> <tr> <td>OFF</td> <td>Shorts out meter.</td> </tr> <tr> <td>DC VOLTS ...</td> <td>Sets up multimeter for dc voltage measurements and selects one of four voltage ranges.</td> </tr> <tr> <td>AC VOLTS ...</td> <td>Sets up multimeter for ac voltage measurements and selects one of three voltage ranges.</td> </tr> <tr> <td>OHMS</td> <td>Sets up multimeter for resistance measurements and selects one of five resistance ranges.</td> </tr> <tr> <td>EXT. SHUNT.</td> <td>Sets up multimeter for measuring current when shorting screw is in closed position.</td> </tr> </tbody> </table>	<i>Switch position</i>	<i>Action</i>	OFF	Shorts out meter.	DC VOLTS ...	Sets up multimeter for dc voltage measurements and selects one of four voltage ranges.	AC VOLTS ...	Sets up multimeter for ac voltage measurements and selects one of three voltage ranges.	OHMS	Sets up multimeter for resistance measurements and selects one of five resistance ranges.	EXT. SHUNT.	Sets up multimeter for measuring current when shorting screw is in closed position.
<i>Switch position</i>	<i>Action</i>												
OFF	Shorts out meter.												
DC VOLTS ...	Sets up multimeter for dc voltage measurements and selects one of four voltage ranges.												
AC VOLTS ...	Sets up multimeter for ac voltage measurements and selects one of three voltage ranges.												
OHMS	Sets up multimeter for resistance measurements and selects one of five resistance ranges.												
EXT. SHUNT.	Sets up multimeter for measuring current when shorting screw is in closed position.												
OHMS ADJ. control.	Adjusts meter pointer to zero (0) on OHMS scale when selector switch is set to one of OHMS ranges.												
Meter	Indicates voltage, resistance, or current value being measured.												

Control or indicator	Function
Shorting screw (fig. 3).	In <i>closed</i> position, sets up multimeter for measuring current when selector switch is in EXT. SHUNT position; in <i>open</i> position, prevents damage to meter if voltage is applied to test leads with selector switch in EXT. SHUNT position.

13. Dc Voltage Measurements (fig. 4)

a. To measure dc voltage up to 1,000 volts, proceed as follows :

- (1) Set the selector switch to the DC VOLTS range that includes the voltage value to be measured.

Caution: If the voltage value to be measured is unknown, set the selector switch to the 1,000-volt range and, if necessary, reduce the setting of the selector switch one step at a time until the meter pointer indicates near the center of the scale.

- (2) Observing polarity, hold the test prods in parallel with the circuit that is being measured. If the meter pointer deflects to the left (below zero), reverse the test prod connections.
- (3) Read the indications on the meter; refer to the following chart and perform the indicated action to determine the measured voltage value.

Range	Action
0 to 1 to 1 volt	Divide meter reading by 10.
0 to 10 volts	Use direct meter reading.
0 to 100 volts	Multiply meter reading by 10.
0 to 1,000 volts ...	Multiply meter reading by 100.

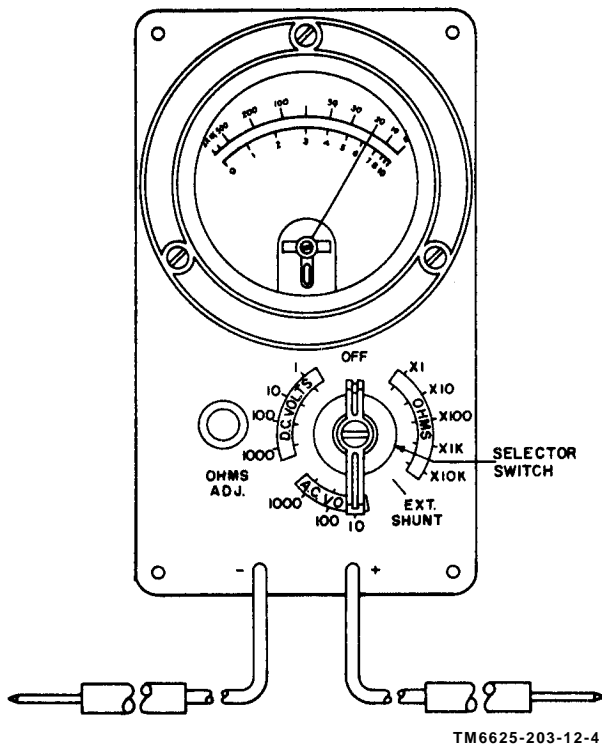

Figure 4. Multimeter ME-77/U, operating controls and indicator.

- (4) Remove the test prods from the circuit.
- (5) Set the selector switch to the highest dc voltage range.

b. To measure dc voltage up to 10,000 volts, refer to paragraph 24a.

c. To measure dc voltage up to 50,000 volts, refer to paragraph 24b.

14. Ac Voltage Measurements

a. Set the selector switch to the AC VOLTS range that includes the voltage value to be measured.

Caution: If the voltage value to be measured is unknown, set the selector switch to the 1,000-volt range and, if necessary, reduce the setting of the selector switch one step at a time until the meter pointer indicates near the center of the scale.

b. Hold the test prods in parallel with the circuit being measured.

c. Read the indication on the meter; refer to the chart in paragraph 13a(3) and perform the

indicated action to determine the measured voltage value.

d. Remove the test leads from the circuit.

e. Set the selector switch to the highest ac voltage range.

15. Resistance Measurements

Caution: Turn off or disconnect the power from the equipment under test when measuring resistance. Damage to the multimeter may result if an external voltage is applied to the multimeter when it is arranged for resistance measurements.

a. Set the selector switch to the desired resistance range.

b. Zero adjust the multimeter before making resistance measurements. Each time the range switch is turned to a different resistance range, repeat the zero adjusting procedure. Zero adjust the multimeter as follows:

- (1) Touch the test lead prods together.
- (2) Turn the OHMS ADJ. control to position the meter pointer at 0 on the right side of the OHMS scale. If the meter pointer cannot be adjusted to 0, replace the batteries (par. 21).

c. Connect the test prods in parallel with the resistance to be measured.

d. Read the meter indication on the OHMS scale and multiply by the factor indicated by the position of the selector switch. For example, if the selector switch is in the X10 position, multiply the meter reading by 10.

e. Remove the test prods from the circuit.

f. If the multimeter is not to be used immediately for additional resistance measurements, place the selector switch in the OFF position.

16. Preparation for Current Measurements

The multimeter *cannot* be used to measure current without an external shunt (par. 22a). To prepare the multimeter for current measurements proceed as follows:

a. Remove the retaining screws that secure the panel to the case and remove the panel.

b. Remove the nut from the shorting screw (fig. 3) and remove the shorting screw from the printed circuit board.

c. Remove the insulating washer (not shown) from the shorting screw.

d. Replace the shorting screw in the printed circuit board; place the insulating washer on the shorting screw and secure the screw with the nut.

e. The shorting screw will now contact the printed circuit and complete the circuit from the test leads to the meter when the selector switch is in the EXT. SHUNT position.

f. Replace the panel in the case and secure the panel with the retaining screws.

g. After current measurements (par. 23) have been completed, place the shorting screw in the open position as follows:

- (1) Remove the panel from the case.
- (2) Remove the nut, insulating washer, and shorting screw from the printed circuit board.

- (3) Place the insulating washer on the shorting screw.

- (4) Replace the shorting screw, with the insulating washer, in the printed circuit board; secure the shorting screw with the nut.

- (5) Replace the panel in the case.

17. Stopping Procedure

a. Set the selector switch (fig. 4) to the OFF position.

b. Coil the test leads and place them on top of the panel.

c. Place the alligator clips (fig. 1) and the electrical clips on top of the panel.

d. Replace the cover and secure it with the metal clasps.

CHAPTER 4

MAINTENANCE INSTRUCTIONS

18. Scope of Organizational Maintenance

a. Organizational maintenance for Multimeter AN/URM-105 consists of the following:

- (1) Preventive maintenance (par. 20).
- (2) Replacement of batteries (par. 21).

b. If the multimeter is inoperative and the batteries are not defective, higher echelon repair is required. Note on the repair tag what corrective measures were taken and how the equipment performed at the time of failure.

19. Tools, Test Equipment, and Materials Required

a. Tools and Test Equipment. The tools and test equipment required are normally available to the repairman-user because of his assigned mission.

b. Materials.

- (1) Cleaning Compound (Federal stock No. 7930-395-9542).
- (2) Lint-free cloth.
- (3) Friction tape.

20. Preventive Maintenance

a. DA Form 11-266. DA Form 11-266 (figs. 5 and 6) is a preventive maintenance check list to be used by organizational maintenance personnel. Items not applicable to the multimeter are lined out in figure 6. References in the ITEM block

are to paragraphs that contain additional maintenance information pertinent to the particular item. Instructions for use of the form appear on the form.

b. Items. The following information supplements DA Form 11-266. The item numbers correspond to the ITEM numbers on the form.

Item	Maintenance procedure
1	Use a clean cloth to remove dust, dirt, moisture, and grease from the case, panel, and test leads. If necessary, wet the cloth with Cleaning Compound and then wipe the parts dry with a clean cloth. Warning: Cleaning Compound is flammable and its fumes are toxic. Do not use near a flame; provide adequate ventilation.
3	Control knobs should work smoothly, be tight on the shafts, and should not bind. Tighten loose knobs and be sure that the knobs do not rub against the panel.
5	Inspect the test leads for obvious defects. If the tips of the test prods are broken, replace them. Repair small cuts in the test-lead insulation with friction tape.
11	Place the multimeter on its back; set the selector switch to the OFF position and observe the position of the meter pointer. The pointer should rest exactly over 0 on the AC and DC VOLTS scale. If the meter pointer does not rest over 0, higher echelon repair is required.

MAINTENANCE CHECK LIST FOR SIGNAL EQUIPMENT TEST EQUIPMENT <small>(AR 750-625)</small>			
EQUIPMENT NOMENCLATURE MULTIMETER AN/URM-105			
EQUIPMENT SERIAL NUMBER 999			
INSTRUCTIONS			
<p>This form may be used for a period of one month by using the correct dates and weeks of the month. It is to be used as a Preventive Maintenance check list for Signal equipment in actual use, or for a check on equipment prior to issue.</p> <ol style="list-style-type: none"> 1. For detailed Preventive Maintenance instructions see: <ol style="list-style-type: none"> a. The Technical Manual (in TM 11 series) for the equipment. <small>(See DA Pamphlet Number 310-4)</small> b. The Supply Bulletin (SB 11-100 series) for the equipment. <small>(See DA Pamphlet Number 310-4)</small> c. The Department of the Army Lubrication Order. <small>(See DA Pamphlet Number 310-4)</small> 2. The following action will be taken by either the Communications Officer/Chief for 1st echelon, or the Inspector for higher echelon: <ol style="list-style-type: none"> a. Enter Equipment Nomenclature and Serial Number. b. Strike out items that do not apply to the equipment. 3. Operator/Inspector will enter in the columns entitled CONDITION, on the proper line, a notation regarding the condition, using symbols specified under LEGEND. 4. After operator completes each daily inspection he will initial over the appropriate dates under "Daily Condition for Month", then return form to his supervisor. 			
TYPE OF INSPECTION			
OPER- ATOR	2/3 ECH- ELON	DATE	SIGNATURE
✓		7 MAY 59	R White
	✓	7 MAY 59	W Black

FOLD

Figure 5. DA Form 11-266, pages 1 and 4.

LEGEND for marking conditions: Satisfactory, ✓. Adjustment, Repair or Replacement required, X. Defect corrected, (X).						DAILY CONDITION FOR MONTH OF MAY														
NO.	DAILY ITEM	1	2	3	4	5	6	7	8	9	10	11	12	13	14	15	16	2D 3D ECH- ELON		
		17	18	19	20	21	22	23	24	25	26	27	28	29	30	31				
	1. CLEAN DIRT AND MOISTURE FROM EXPOSED SURFACES OF HOUSINGS, CASES, GASKETS, CONTROL PANELS, INTERCONNECTING PLUGS, CABLES, HEADERS, METER WINDOWS, ETC. PAR. 20b	✓	✓	✓	✓	✓	✓	✓	✓	✓	✓	✓	✓	✓	✓	✓	✓	✓	✓	
	2. INSPECT FOR LOOSENESS OF EXTERIOR ITEMS SUCH AS SWITCHES, KNOBS, JACKS, CONNECTORS AND PILOT LIGHTS.	✓	✓	✓	✓	✓	✓	✓	✓	✓	✓	✓	✓	✓	✓	✓	✓	✓	✓	
	3. INSPECT CONTROLS FOR BINDING, SCRAPING. TAP CONTROLS LIGHTLY FOR CUT-OUT DUE TO LOOSE CONTACTS. PAR. 20b	✓	✓	✓	✓	✓	✓	✓	✓	✓	✓	✓	✓	✓	✓	✓	✓	✓	✓	
	4. DURING OPERATION BE ALERT FOR ANY UNUSUAL PERFORMANCE OR CONDITION.	✓	✓	✓	✓	✓	✓	✓	✓	✓	✓	✓	✓	✓	✓	✓	✓	✓	✓	
WEEKLY		CONDITION EACH WEEK					2D 3D ECH	ADDITIONAL ITEMS FOR 2D AND 3D ECHELON INSPECTIONS											CONDITION	
	5. INSPECT CORDS, CABLES, WIRE AND SHOCK MOUNTS FOR BREAKS, CUTS, KINKS, DETE-RIORATION, STRAIN AND FRAYING. PAR. 20b	(X)					✓	15. INSPECT RESISTORS, Bushings, INSULATORS FOR CRACKS, CHIPPING, BLISTERING, DISCOLORATION AND MOISTURE.												✓
	6. INSPECT CANVAS AND LEATHER ITEMS FOR FUNGUS, FRAYING, TEARS, BROKEN SEWERS AND SHIP FASTENERS.							16. INSPECT JACKS AND CONNECTORS FOR SNUG FIT AND GOOD CONTACTS.												
	7. HAND CHECK FOR LOOSENESS OF EXTERIOR ITEMS SUCH AS HANDLES, LATCHES, WINDS.		✓				✓	17. INSPECT VARIABLE CAPACITORS FOR DIRT AND MOISTURE.												
	8. INSPECT FOR LUBRICATION IN ACCORDANCE WITH APPLICABLE MAINTENANCE ORDER.							18. INSPECT AIR FILTERS FOR CLEANLINESS.												
	9. INSPECT DRY BATTERIES FOR DIRT, LOOSE TERMINALS AND LEAKAGE.		✓				✓	19. INSPECT SCREW-TYPE TERMINALS OF TRANSFORMERS, FIRED CAPACITORS, RESISTORS, SHOCKS, POTENTIOMETERS AND RHEOSTATS FOR CORROSION, DIRT AND LOOSE CONTACTS.												
	10. INSPECT EXPOSED METAL SURFACES FOR RUST AND CORROSION.							20. CLEAN AND TIGHTEN SWITCHES, BLOWERS-RELAY CASES; CLEAN INTERIOR OF CHASSIS AND CABINETS.												✓
	11. INSPECT METERS FOR DAMAGED GLASS AND CASES. PAR. 20b		X				X	21. INSPECT GENERATORS, MOTORS AND DYNAMOTORS FOR BRUSH WEAR, SPRING TENSION, ARcing AND COMMUTATOR WEAR.												
	ADDITIONAL ITEMS FOR 2D AND 3D ECHELON INSPECTIONS						CONDITION	22. INSPECT TERMINAL BLOCS FOR LOOSE CONNECTIONS, CRACKS AND BREAKS.												
	12. INSPECT SEATING OF READILY ACCESSIBLE ITEMS OF A PLUG-OUT NATURE, CRYSTALS, TUBES, CONNECTORS, PLUG-IN COILS, LAMPS, ETC. DO NOT REMOVE, ROCK OR TILT TO INSPECT. USE ONLY A DIRECT PRESSURE TO INSURE THE ITEM IS FULLY SEATED.							23. INSPECT GASKETS AND BUSHINGS FOR WEAR AND DAMAGE.												✓
	13. INSPECT FOR CLEANLINESS AND TIGHTNESS OF SUCH ITEMS AS SHOCK MOUNTS, ANTENNA, ANTENNA MOUNTS AND WAVE GUIDES.							24. INSPECT CATHODE RAY TUBES FOR BURNED SCREEN SPOTS.												
	14. INSPECT RELAY AND CIRCUIT BREAKER ASSEMBLIES FOR DIRT, CORROSION, WORN OR BURNED CONTACTS.							25. BEFORE STORING OR SHIPPING - REMOVE ALL BATTERIES.												✓
IF DEFICIENCIES NOTED ARE NOT CORRECTED DURING THE INSPECTION, INDICATE ACTION TAKEN FOR CORRECTION. (Continue on page 4, if more space is needed) ITEM 11. METER POINTER RESTS BELOW ZERO. REPORTED TO HIGHER ECHELON FOR REPAIR.																				

Figure 6. DA Form 11-266, pages 2 and 3.

21. Replacement of Batteries

a. Check for sufficient battery voltage as follows :

- (1) Set the selector switch (fig.4) to OHMS X1.
- (2) Touch the tips of the test prods together; the meter pointer should deflect to the right.
- (3) Turn the OHMS ADJ. control to its maximum clockwise position; the meter pointer should deflect to zero (0) or to the right of zero on the OHMS scale. If the meter pointer does not deflect to zero or to the right of zero, replace Batteries BA-58/U (*b* below).
- (4) Set the selector switch to OHMS X1K and check to be sure that the tips of the test prods are touching. The meter

pointer should deflect to zero or to the right of zero. If the meter pointer does not deflect to zero or to the right of zero, replace Battery BA-261/U (*b* below).

- (5) Set the selector switch to OFF, separate the test prods, and turn the OHMS ADJ. control to its maximum counterclockwise position.

b. Replace the batteries as follows:

- (1) Remove the retaining screws that secure the panel to the case and remove the panel.
- (2) Replace the batteries as required.
- (3) Replace the panel in the case but do not secure the panel.
- (4) Repeat the checking procedure in *a* above.
- (5) Secure the panel with the retaining screws.

CHAPTER 5

AUXILIARY EQUIPMENT

22. Description and Use of Auxiliary Equipment

a. Multirange Instrument Shunt MX-1471/U (fig. 7). Multirange Instrument Shunt MX-1471/U (shunt) contains seven precision shunt resistors accessible from terminals on the panel. The MX-1471/U enables the multimeter to be used for dc current measurements (par. 23) in seven ranges as follows:

- (1) 0 to 100 microampere.
- (2) 0 to 1 milliamperes.
- (3) 0 to 10 milliamperes.
- (4) 0 to 100 milliamperes.
- (5) 0 to 1 ampere.
- (6) 0 to 10 amperes.

Caution: Do not use Test Lead Set CX-1331/U for current measurements greater than 10 amperes. The size of the wire used in the test leads will not safely handle more than 10 amperes

- (7) 0 to 100 amperes.

b. Electrical Instrument Multiplier MX-1472/U (fig. 8). Electrical Instrument Multiplier MX-1472/U contains a precision resistor assembly terminated at one end with an alligator clip and at the other end with a tip jack. The MX-1472/U enables the multimeter to be used for dc voltage measurements up to 10,000 volts (par. 24a).

c. Electrical Instrument Multiplier MX-2005/U (fig. 8). Electrical Instrument Multiplier MX-2005/U is similar to the MX-1472/U (*b* above) except that it enables the multimeter to be used for dc voltage measurements up to 50,000 volts (par. 24b).

23. Direct Current Measurements

Caution: When measuring current, always connect the multimeter in series with the circuit under test. Be sure that the test lead polarity is observed (black is negative and red is positive). Wrong connections may damage the meter.

a. Place the shorting screw in the closed position (par. 16).

b. Connect the multimeter and the shunt as follows :

- (1) Select the appropriate current range (par. 22a).

Caution: If the current value to be measured is not known, connect the multimeter and the shunt to measure current on the highest range. Perform the procedures in *c* through *g* below to determine the approximate current value to be measured. Turn off the equipment under test and reconnect the multimeter and shunt using the appropriate current range.

- (2) Connect Test Lead Set CX-1331/U to the terminals on the shunt; connect the black lead to the black (COMMON) terminal and the red lead to the red terminal corresponding to the selected current range ((1) above).

Caution: Do not use Test Lead Set CX-1331/U for current measurements greater than 10 amperes. The size of the wire used in the test leads will not safely handle more than 10 amperes.

- (3) Connect the multimeter leads to the front of the terminals ((2) above); insert the tip of the black test prod into the black terminal and the tip of the red test prod into the red terminal.

c. Check to be sure that the power has been turned off or disconnected from the equipment under test.

d. Observing polarity, connect the test leads in series with the circuit under test. Connect the test leads so that electrons enter through the black test prod and return through the red test prod.

e. Set the selector switch (fig. 4) to the EXT. SHUNT position.

f. Turn on the equipment under test.

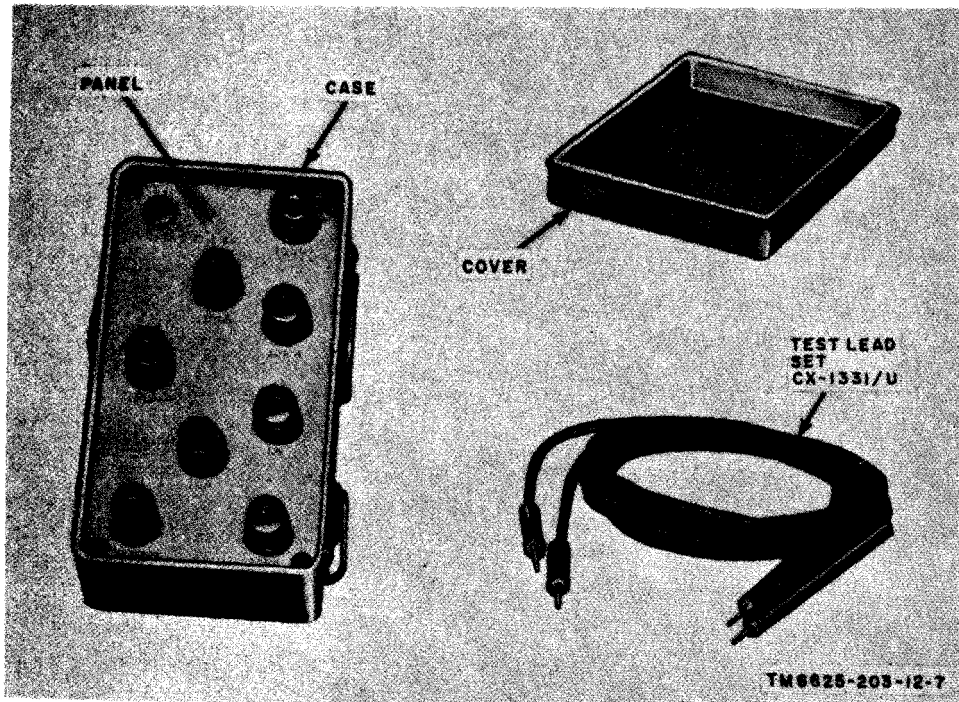

Figure 7. Multirange Instrument Shunt MX-1471/U.

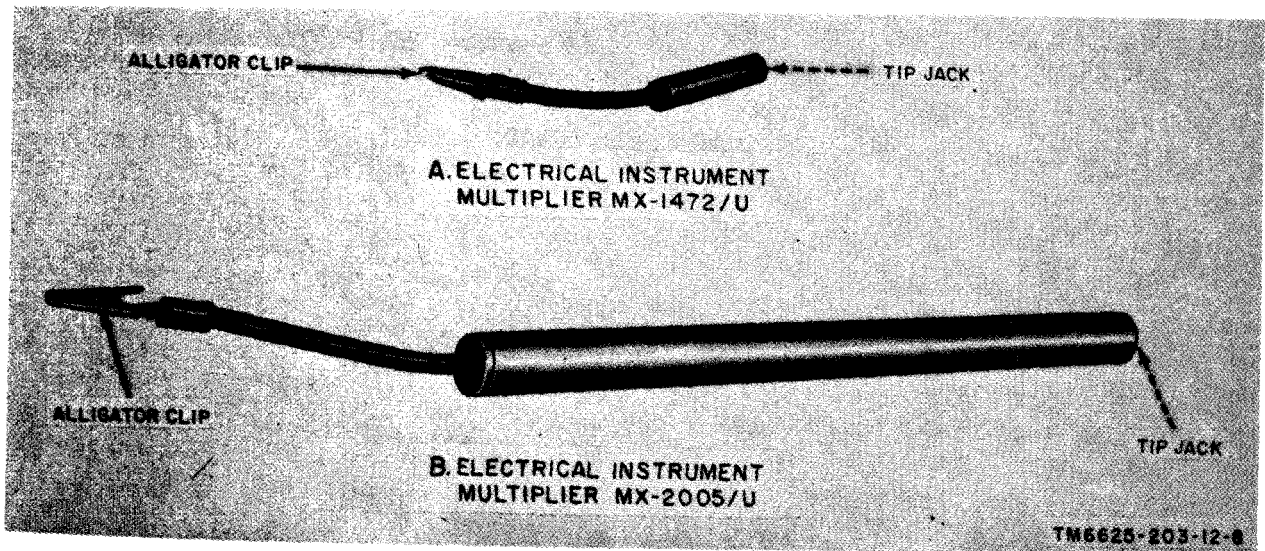

Figure 8. Electrical Instrument Multiplier MX-1472/U and Electrical Instrument Multiplier MX-2005/U.

g. Read the indication on the meter; refer to the following chart and perform the indicated action to determine the measured current value.

Shunt range	Action
0 to 100 UA.....	Multiply meter reading by 10; current in microamperes.
0 to 1 MA.....	Divide meter reading by 10; current in milliamperes.
0 to 10 MA.....	Use direct meter reading; current in milliamperes.
0 to 100 MA.....	Multiply meter reading by 10; current in milliamperes.
0 to 1 A.....	Divide meter reading by 10; current in amperes.
0 to 10 A.....	Use direct meter reading; current in amperes.
0 to 100 A.....	Multiply meter reading by 10; current in amperes.

h. Turn off the equipment under test and disconnect the test leads from the circuit.

i. After current measurements have been completed, shut down the equipment as follows:

- (1) Set the selector switch (fig. 4) to the OFF position.
- (2) Remove the test leads (fig. 9) and the multimeter leads from the shunt.
- (3) Place the shorting screw in the open position (par. 16g).

24. High Voltage Measurements

Warning: When measuring high voltages, always turn off or disconnect the power from the equipment under test. Connect the test prods, turn on the equipment, and note the meter indication. *Do not handle any part of the equipment when the power is on.*

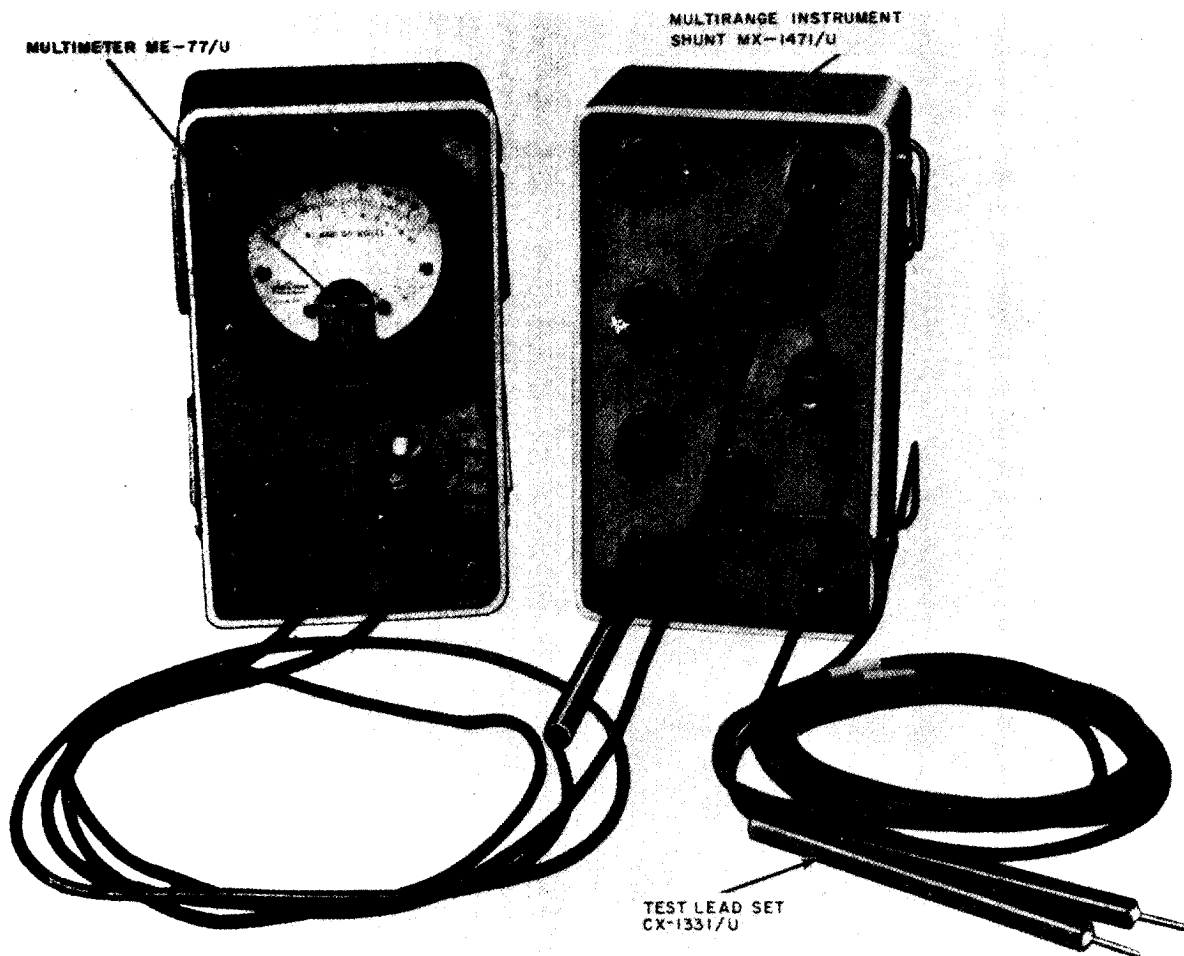

TM6625-203-12-9

Figure 9. Multimeter ME-77/U and Multirange Instrument Shunt MX-4171/U connected for current measurements.

a. Dc Voltage Measurements up to 10,000 Volts.

Warning: Discharge all high voltage capacitors in the equipment being checked before connecting or disconnecting the test prods.

- (1) Connect the tip of the red test prod into the tip jack on the MX-1472/U.
- (2) Connect the black alligator clip to the black test prod.
- (3) Set the selector switch (fig. 4) to the 1000 DC VOLTS range.
- (4) Check to be sure that the power has been turned off or disconnected from the equipment under test.
- (5) Observing polarity, connect the alligator clips in parallel with the circuit being measured.
- (6) Turn on the equipment under test.
- (7) Read the indication on the meter; multiply the meter indication by 1,000 to determine the measured voltage value.
- (8) Turn off the equipment under test and discharge the high voltage capacitors.

- (9) Disconnect the alligator clips from the circuit being checked.

b. Dc Voltage Measurements up to 50,000 Volts.

Warning: Discharge all high voltage capacitors in the equipment being checked before connecting or disconnecting the test prods.

- (1) Connect the tip of the red test prod into the tip jack on the MX-2005/U.
- (2) Perform the procedures in a(2) through (6) above.
- (3) Read the indication on the meter; multiply the meter by 10,000 to determine the measured voltage value.

Caution: The resistor assembly used in the MX-2005/U will enable voltage measurements up to 100,000 volts; however, insulation resistance of the MX-2005/U limits the maximum voltage that can be measured to 50,000 volts.

- (4) Turn off the equipment under test and discharge the high voltage capacitors.
- (5) Disconnect the alligator clips from the circuit being checked.

CHAPTER 6

SHIPMENT, LIMITED STORAGE, AND DEMOLITION TO PREVENT ENEMY USE

Section I. SHIPMENT AND LIMITED STORAGE

25. Disassembly of Equipment

- a. Remove the panel from the case.
- b. Remove the batteries from the battery holder.
- c. Replace the panel.
- d. Coil the test leads and place them on top of the panel.
- e. Place the alligator clips and the electrical clips on top of the panel.
- f. Place the cover on the multimeter and secure the cover with the metal clasps.

26. Repackaging for Shipment or Limited Storage.

The exact procedure for repackaging depends on the material available and the conditions under which the equipment is to be shipped or stored. Adapt the procedures outlined below whenever circumstance permit. The information concerning the original packaging (par. 8) will also be helpful.

a. *Material Requirements.* The following materials are required for packaging Multimeter AN/URM-105. For stock numbers of materials, consult SB 88-100 (Preservation, Packaging and Packing Materials, Supplies, and Equipment used by the Army).

Material	Quantity
Waterproof paper -----	6 sq ft
Waterproof tape -----	10 ft
Corrugated cardboard -----	10 sq ft
Gummed tape-----	4 ft
Filler material-----	1 lb

b. Packaging.

- (1) Cushion the multimeter with pads of filler material on all sides. Place the cushioned unit within a wrap of corrugated cardboard and secure the ends with gummed tape.
- (2) Package each technical manual within a close-fitting bag fabricated of waterproof paper; seal the bags with waterproof tape.
- (3) Use corrugated cardboard and form a carton large enough to hold the packaged multimeter and technical manuals. Line the carton with waterproof paper. Place the package in the carton and fill all voids with filler material. Seal the waterproof carton liner with waterproof tape; seal the carton with gummed tape.

Section II. DEMOLITION OF MATERIEL TO PREVENT ENEMY USE

27. Authority for Demolition

The demolition procedures in paragraph 28 will be used to prevent the enemy from using or salvaging this equipment. Demolition of the equipment will be accomplished only upon the order of the commanding officer,

28. Methods of Destruction

The size and construction of the multimeter par-

ticularly lends itself to destruction by smashing.

a. Use sledges axes, hammers, crowbars, or any heavy tool available to wash the multimeter; if time permits, remove the panel from the case before smashing.

b. Burn technical manuals.

c. Bury or scatter the destroyed parts in slit trenches, foxholes, or throw them into streams.

APPENDIX I

REFERENCES

SB 38-100 Preservation, Packaging and Packing Materials, Supplies, and Equipment Used by the Army.

TM 11-6605-203-12P Operator's and Organizational Maintenance Repair Parts and Special Tools List for Multimeter AN/URM-105.

APPENDIX II

MAINTENANCE ALLOCATION CHART POR MULTIMETER AN/URM-105

1. General

a. This appendix assigns maintenance functions and repair operations to be performed by the lowest appropriate maintenance echelon. It also specifies the tools and other equipment authorized at each echelon to perform the assigned maintenance function.

b. Columns in Maintenance Allocation Chart are as follows:

- (1) *Part or component.* Only the nomenclature or standard item name is shown in this column. Additional descriptive data is included only where clarification is necessary to identify the part. Components and parts comprising a major end item are listed alphabetically. Assemblies and subassemblies are in alphabetical sequence, with their components listed alphabetically immediately below the assembly listing.
- (2) *Maintenance function.* This column indicates the various maintenance functions allocated to the echelon capable of performing the operation.
 - (a) *Service.* To clean, to preserve and to replenish fuel and lubricants.
 - (b) *Inspect.* To verify serviceability and to detect incipient electrical or mechanical failure by scrutiny.
 - (c) *Test.* To verify serviceability and to detect incipient electrical or mechanical failure by use of special equipment, such as gages and meters.
 - (d) *Replace.* To substitute serviceable assemblies, subassemblies, and parts for unserviceable components.
 - (e) *Repair.* To restore to a serviceable condition by replacing unserviceable parts or by any other action required, utilizing tools, equipment, and skills available. Repairs include welding, grinding, riveting, straightening, adjusting, etc.

(f) *Calibrate.* To determine, check, or rectify the graduation of an instrument, weapon, or weapons system, or components thereof.

(g) *Rebuild.* To restore to a condition comparable to new by disassembling the item to determine the condition of its component parts. To reassemble it by using serviceable, rebuilt, or new assemblies, subassemblies, and parts.

(3) *1st, 2nd, 3rd, 4th, 5th echelon.* The symbol X indicates the echelon responsible for performing that particular maintenance operation. It does not necessarily indicate that repair parts will be stocked at that level. Echelons higher than the echelon marked by X are authorized to perform the indicated operation.

(4) *Tools required.* The numbers in this column indicate the tool and test equipment required to perform the maintenance functions. These numbers are identified in the Allocation of Tools for Maintenance Functions.

(5) *Remarks.* This column contains any notations necessary to clarify the data cited in the preceding columns.

c. Columns in the Allocation of Tools for Maintenance Functions, are as follows:

(1) *Tools required for maintenance functions.* This column lists tool and test equipments required to perform the maintenance functions.

(2) *1st, 2nd, 3rd, 4th, 5th echelon.* The dagger (†) indicates the echelon to which tool or test equipment is allocated.

(3) *Tool code.* The numbers in this column are code numbers for the associated tool equipment and are used in the Maintenance Allocation Chart to refer to the indicated item.

(4) *Remarks.* This column contains no notations necessary to clarify data in the preceding columns.

2. Maintenance by Using Organizations

Maintenance functions allocated up to and including fourth echelon are authorized to the or-

ganization operating this equipment, when used by signal service organizations organic to theater headquarters, or communication zones, to provide theater communications.

MAINTENANCE ALLOCATION CHART

(1)	(2)	(3)	(4)	(5)	(6)	(7)	(8)	(9)
PART OR COMPONENT	MAINTENANCE FUNCTION	1ST ECH.	2ND ECH.	3RD ECH.	4TH ECH.	5TH ECH.	TOOLS REQUIRED	REMARKS
MULTIMETER AN/URM-105	repair rebuild service inspect test calibrate	X	X	X	X	X	1, 2, 3, 4 1, 2, 3, 4	Code 2, 4 only at 2nd and 3rd echelon.
CLIPS, ELECTRICAL	replace		X					
MULTIMETER ME-77/U	repair rebuild service inspect test calibrate	X	X	X	X	X	1, 2, 3, 4 1, 2, 3, 4	Code 2, 4 only at 2nd and 3rd echelon.
BOARD, PRINTED CIRCUIT	replace				X			
CASE, METER	replace				X			
COVER	replace		X					
GASKET	replace		X					
HOLDER, SPRING	replace		X					
KNOBS	replace		X					
SCREW, MACHINE	replace		X					
LEAD, TEST	repair		X					
CABLE	replace			X				
TIP, TEST LEAD	replace		X					
NUTS (common hardware)	replace			X				Available in Maintenance Equipment ME-9 and Hardware Kit MK-41/U
PANEL, MOUNTING	replace				X			
RECTIFIER, METALLIC	replace				X			
RESISTORS	replace				X			
SCREWS (common hardware)	replace			X				Available in Maintenance Equipment ME-9 and Hardware Kit MK-41/U
SWITCH, ROTARY	replace				X			
TERMINAL BOARD	replace				X			Fabricate
VOLTMETER	replace repair				X	X		
WASHERS (common hardware)	replace			X				Available in Maintenance Equipment ME-9 and Hardware Kit MK-41/U

ALLOCATION OF TOOLS FOR MAINTENANCE FUNCTIONS

(1) TOOLS REQUIRED FOR MAINTENANCE FUNCTIONS	(2) 1ST ECH.	(3) 2ND ECH.	(4) 3RD ECH.	(5) 4TH ECH.	(6) 5TH ECH.	(7) TOOL CODE	(8) REMARKS
AN/URM-105							
METER TEST EQUIPMENT AN/GSM-16				+		1	Second and third level maintenance will be performed at forth echelon
MULTIMETER AN/URM-105				+		2	
TEST SET, ELECTRON TUBE TV-6/U				+		3	
TOOL EQUIPMENT TK-21/G				+		4	

By Order of *Wilber M. Brucker*, Secretary of the Army:

MAXWELL D. TAYLOR,
General, United States Army,
Chief of Staff.

Official:

R. V. LEE,
Major General, United States Army,
The Adjutant General.

Distribution:

Active Army:

ASA (2)	Midwestern Rgn Ofc (TASSA)	8-500 (AA-	17-48 (2)
CNGB (1)	(15)	AH) (2)	17-57 (2)
Tech Stf, DA (1) except	USA Elct PG (1)	9-22 (2)	17-87 (2)
C SigO (30)	Dugway PG (5)	9-47 (2)	19-35 (2)
Tech Stf Bd (1)	Aberdeen PG (5)	9-65 (2)	19-37 (2)
USCONABO (5)	Pine Bluff Arsenal (5)	9-66 (2)	19-55 (2)
USA Arty Bd (1)	Rocky Mt Arsenal (5)	9-86 (2)	19-57 (2)
USA Armor Bd (1)	Benicia Arsenal (5)	9-217 (2)	19-217 (2)
USA Inf Bd (1)	Raritan Arsenal (5)	9-377 (2)	30-15 (2)
USA AD Bd (1)	William Beaumont AH (5)	10-22 (2)	30-19 (2)
USA Abn & Elct Bd (1)	Fitzsimons AH (5)	10-536 (2)	30-21 (2)
USA Avn Bd (1)	Brooke AH (5)	11-5 (2)	30-22 (2)
USA ATB (1)	Sig Fld Maint Shops (3)	11-6 (2)	33-77 (2)
USA Armor Bd Test Sec (1)	USA Med Rsch Lab (5)	11-7 (2)	39-61 (2)
USA AD Bd Test Sec (1)	Sig Lab (5)	11-8 (2)	39-71 (2)
US ARADCOM (2)	USA Sig Svc Team (1)	11-15 (2)	44-8 (2)
US ARADCOM Rgn (2)	Mil Dist (1)	11-16 (2)	44-12 (2)
OS Maj Comd (5)	USA Corps (Res) (1)	11-17 (2)	44-15 (2)
OS Base Comd (5)	Sector Comd, USA (Res) (1)	11-18 (2)	44-16 (2)
Log Comd (5)	JBUSMC (2)	11-39 (2)	44-17 (2)
Ord Msl Comd (3)	Mil Man (2)	11-45 (2)	44-35 (2)
Ord SW Comd (5)	Units organized under following	11-46 (2)	44-36 (2)
MDW (1)	TOE's:	11-54 (2)	44-37 (2)
Armies (5) except	1-107 (2)	6-325 (2)	11-55 (2)
First USA (7)	1-207 (2)	6-326 (2)	11-56 (2)
Corps (2)	5-15 (2)	6-401 (2)	11-57 (2)
Div (2)	5-16 (2)	6-415 (2)	11-58 (2)
USATC (2)	5-17 (2)	6-416 (2)	11-67 (2)
Svc Colleges (5)	5-35 (2)	6-435 (2)	11-68 (2)
Br Svc Sch (5) except	5-36 (2)	6-500 (2)	11-85 (2)
USASCS (25)	5-37 (2)	6-501 (2)	11-86 (2)
GENDEP (2) except	5-138 (2)	6-525 (2)	11-87 (2)
Atlanta GENDEP (none)	5-215 (2)	6-535 (2)	11-97 (2)
Sig Sec, GENDEP (12)	5-216 (2)	6-536 (2)	11-98 (2)
Sig Dep (19)	5-217 (2)	6-537 (2)	11-117 (2)
AFIP (1)	5-218 (2)	6-545 (2)	11-155 (2)
WRAMC (1)	5-348 (2)	6-545 (2)	11-157 (2)
BAMC (5)	5-372 (2)	6-585 (2)	11-158 (2)
USA SW Cen (5)	5-376 (2)	6-631 (2)	11-500 (AA
Engr Maint Cen (1)	5-600 (2)	6-635 (2)	AE) (2)
Army Pictorial Cen (2)	5-605 (2)	7-11 (2)	11-587 (2)
Yuma Test Sta (2)	5-617 (2)	7-12 (2)	11-592 (2)
Ports of Emb (OS) (2)	5-627 (2)	7-15 (2)	11-597 (2)
Trans Terminal Comd (1)	6-100 (2)	7-16 (2)	11-608 (2)
Army Terminals (1)	6-101 (2)	7-25 (2)	17-2 (2)
OS Sup Agcy (2)	6-125 (2)	7-26 (2)	17-17 (2)
Fld Comd, Def Atomic Spt Agcy	6-126 (2)	7-27 (2)	17-22 (2)
(5)	6-136 (2)	7-52 (2)	17-25 (2)
USA Comm Agcy (2)	6-300 (2)	8-15 (2)	17-26 (2)
USA Sig Engr Agcy (1)	6-301 (2)	8-16 (2)	17-27 (2)
USA Sig Eqp Spt Agcy (2)	6-315 (2)	8-75 (2)	17-32 (2)
USA Sig Msl Spt Agcy (13)	6-316 (2)	8-76 (2)	17-45 (2)
USA Sig Pub Agcy (8)			55-129 (2)
TASSA (15)			

NG: State AG (3); units—same as Active Army except allowance is one copy to each unit.

USAR: None.

For explanation of abbreviations used, see AR 320-50.

